

The Kathrein RRU 4560 reader is the next generation of RAIN RFID readers and the leading IoT device for all professional AutoID solutions. It is the first choice for professional IoT solutions, such as industrial automation and vehicle identification in ruggedised environments.

Its best-in-class 33-dBm UHF RF unit, embedded BLE and WiFi connectivity modules, and the powerful scalable processing unit change the way identification works.

Based on the latest RFID standards, such as EPC Gen2v2/ISO 18000-63, Kathrein RRU 4560 reader supports all market leading transponder chip features for security, authentication and encoding.



Features

- ruggedised high-end RAIN RFID reader
- powerful IoT gateway
- enhanced RF design
- integrated high secure memory module
- 4 antenna ports
- +33 dBm port power
- @KRAI antenna support
- GPIO
- PoE+
- Wi-Fi
- Bluetooth
- basic computing module
- embedded dual-core 800 MHz PC
- open source Linux OS
- advanced LED visualisation
- IP67 outdoor use
- type approval for Europe, US and RoW

Key Applications

- Manufacturing and Automotive
- Logistics
- Track & Trace
- Intelligent Transportation Systems
- Healthcare

Dimensions [mm]

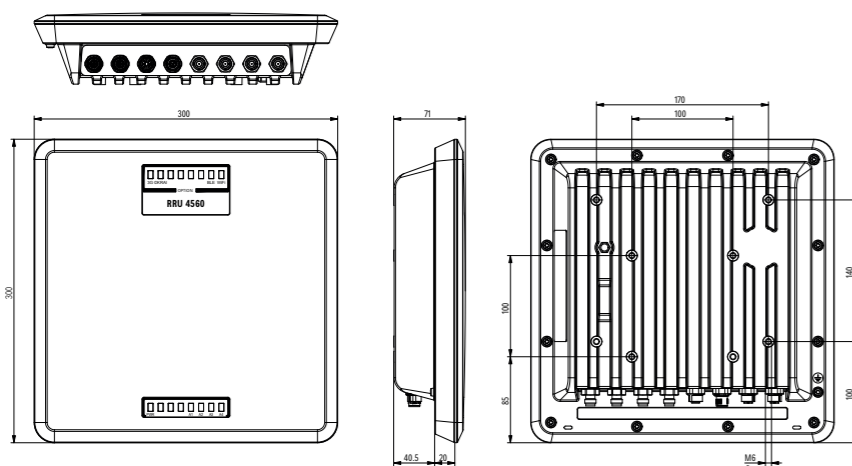

Note

Risk of material damage!

- ▶ Make sure that the depth at which the screws are put into the housing of the reader does not exceed 10 mm (the tightening torque is 5 Nm).

General Specifications

Type		ETSI Version RRU 4560	FCC Version RRU 4560
Order number		52010289	52010297
RFID			
Frequency range	[MHz]	865–868	902–928
Impedance antenna port	[Ohm]	50	
Max. TX power, conducted	[dBm]	33	30 (33 dBm with extended cable length)
Max. TX power, radiated	[ERP (ETSI)/ EIRP (FCC)]	33	36
RX sensitivity	[dBm]	typ. –80	
Number of antenna ports	[R-TNC]	4	
Standards		EN302208-2 V2.1.1, EN301489-3, EN50364, EN62368-1, EN60529, EPC Gen2 V2, UCODE DNA	FCC Part15, UL, IC, EPC Gen2 V2, UCODE DNA
Voltage			
Local supply	[VDC]	+10 to +30	
Connector		M12, A-coded, 4-pole	
Remote feed	[VDC]	PoE+ according to 802.3at (35–57) <ul style="list-style-type: none"> ▶ Make sure that the router/switch supports 30 W in the static mode. ▶ Use the cable the length of which does not exceed 100 m. ▶ Make sure to use a Cat 6 cable or a higher level cable. ▶ Note that the internal supply of GPIO-VCC-pin is not possible with PoE+. 	
Connector		M12, X-coded, 8-pole, port 1 only	
Power consumption			
Local supply	[W]	25.4	
Remote feed	[W]	25.4	
Embedded PC			
Processor		ARMv7-A based processor, 2 cores @ 800 MHz	
Flash memory (eMMC)	[Gbyte]	8	
RAM DDR3	[Gbyte]	1	
Operating system		Linux	
Ethernet			
Number of Ethernet ports		2	
Datarate	[Mbit/s]	10/100	
Connector		M12, X-coded, 8-pole	
©KRAI			
TX Frequency	[kHz]	22	
Supply voltage (output)	[V]	5	
Max. current per port	[mA]	100	
LED visualisation			
Freely programmable		12	
Fixed		1 (power LED)	

> General Specifications

Type	ETSI Version RRU 4560	FCC Version RRU 4560
Order number	52010289	52010297
Wi-Fi		
Supported standards		a, b, g, n
2.5 GHz band	[GHz]	2.412–2.484
Max. TX power (dependent on country)	[dBm]	max. 17.3
5 GHz band	[GHz]	4.910–5.825
Max. TX power (dependent on country)	[dBm]	max. 18
Max. channel bandwidth	[MHz]	max. 40
Bluetooth		
Frequency range	[GHz]	2.402–2.480
Max. TX power	[dBm]	11.7
GPIO		
Type		4 inputs, 4 outputs (double insulation possible)
Max. input voltage	[V]	30
Max. output voltage	[V]	30
Max. current per output port	[mA]	500
Max. current over all outputs	[mA]	1500
Connector		M12, A-coded, 12-pole
RFID controller		
Processor		ARMv7-A based processor with 600 MHz
Flash memory eMMC	[Gbyte]	4
RAM DDR2	[Mbyte]	128
Operating system		Linux
Mechanical properties		
Weight	[kg]	4.00
Degree of protection		IP67
Operating temperature range	[°C]	-20 to +55
Storage temperature range	[°C]	-40 to +85
Dimensions (L x W x H)	[mm]	300 x 300 x 71

> Power Supply

M12, A-coded, 4-pin, male

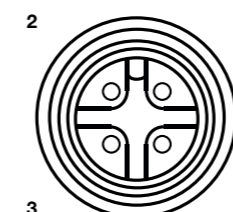

Pinout Power Supply

Pin	Allocation
1	+24 V DC
2	GND
3	GND
4	+24 V DC

> Ethernet

M12, X-coded, 8-pin, female

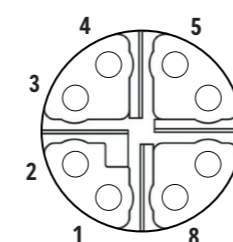

Pinout communication PoE+

Pin	Data	PoE
1	TX+	PoE Mode A
2	TX-	PoE Mode A
3	RX+	PoE Mode A
4	RX-	PoE Mode A
5		PoE Mode B
6		PoE Mode B
7		PoE Mode B
8		PoE Mode B

> GPIO

M12, A-coded, 12-pin, female

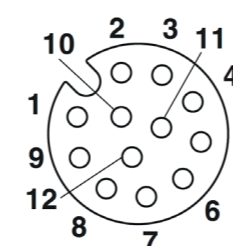

Pinout general purpose input output

Pin	Allocation	Pin	Allocation
1	OUT_CMN	7	UB
2	OUTPUT_1	8	OUTPUT_4
3	INPUT_3	9	OUTPUT_3
4	INPUT_CMN	10	OUTPUT_2
5	INPUT_1	11	INPUT_2
6	GND	12	INPUT_4